

1.5T Hydraulic Transmission Jack



IMPORTANT! PLEASE READ THESE INSTRUCTIONS CAREFULLY. NOTE ALL SAFETY INSTRUCTIONS AND WARNINGS. USE THE PRODUCT CORRECTLY AND WITH CARE FOR THE PURPOSE FOR WHICH IT IS INTENDED. FAILURE TO FOLLOW THESE INSTRUCTIONS MAY CAUSE DAMAGE TO PROPERTY AND/OR PERSONAL INJURY.

PLEASE KEEP THESE INSTRUCTIONS SAFE AND AVAILABLE FOR FUTURE REFERENCE.

CERTIFICATE OF GUARANTEE

This product is guaranteed for a period of 2 Years, with effect from the date of purchase and applies only to the original purchaser. This guarantee only applies to defects arising from, defective materials and or faulty workmanship that become evident during the guarantee period only and does not include consumable items. The manufacturer will repair or replace the product at their discretion subject to the following. That the product has been used in accordance with the guidelines as detailed in the product manual and that it has not been subjected to misuse, abuse or used for a purpose for which it was not intended. That it has not been taken apart or tampered with in any way whatsoever or has been serviced by unauthorised persons or has been used for hire purposes. Transit damage is excluded from this guarantee. Claims made under this guarantee must be made in the first instance, directly to the retailer within the guarantee period. Only under exceptional circumstances should the product be returned to the manufacturer. In this case it may be the consumer's responsibility to return the product at their cost ensuring that the product is adequately packed to prevent transit damage and must be accompanied with a brief description of the fault and a copy of the receipt or other proof of purchase. The manufacturer shall not be liable for any special, exemplary, direct, indirect, incidental, or consequential loss or damage under this guarantee.

INTRODUCTION

Thank you for purchasing this product which has passed through our extensive quality assurance process. Every care has been taken to ensure that it reaches you in perfect condition. However, in the unlikely event that you should experience a problem, or if we can offer any assistance or advice please do not hesitate to contact our customer care department. For details of your nearest customer care department please refer to the telephone numbers at the back of this manual.

Safety First

Before attempting to operate this product the following basic safety precautions should always be taken to reduce the risk of fire, electric shock and personal injury. It is important to read the instruction manual to understand the application, limitations and potential hazards associated with this product.

HELPLINE & SPARE PARTS

In the unlikely event of a defect occurring please contact our Helpline.
Office hours: Monday - Friday 9:00am - 5:00pm. Telephone Number 01332 576 850

TECHNICAL SPECIFICATIONS

Item	STJV1500
Capacity:	1500 kg
Min. Height:	190mm
Max. Height:	840mm

SAFETY INSTRUCTIONS

WARNING!

1. The jack may be used for the installation / removal of transmission systems within the weight limitations specified.
2. The jack is designed for lifting / lowering vehicle transmissions and differentials only.
3. Always transport transmissions / differentials on the jack in its lowest possible height.
4. Never use the jack to lift a vehicle.
5. Ensure that the vehicle transmission is stable within the saddle of the transmission jack before lifting or lowering it.
6. The jack should be supported on a solid, level and horizontal surface which is well illuminated and free of obstructions. Never stand the jack on a surface which may sink, concrete is preferred.
7. Inspect and lubricate the jack on a regular basis.
- 8 Failure to comply with these safety warnings may result in personal injury and / or damage to property and jack.

MAINTENANCE

- The hydraulic system is a closed system and will normally demand no maintenance.
- The mechanical parts of the pedal must be frequently lubricated with a high-quality oil.
- The oil level must not exceed the filling plug when the transmission jack is in its lowest position.
- When the lifting saddle can be pumped up to the top position the hydraulic system is filled with enough oil.

EXPLODED PARTS DIAGRAM

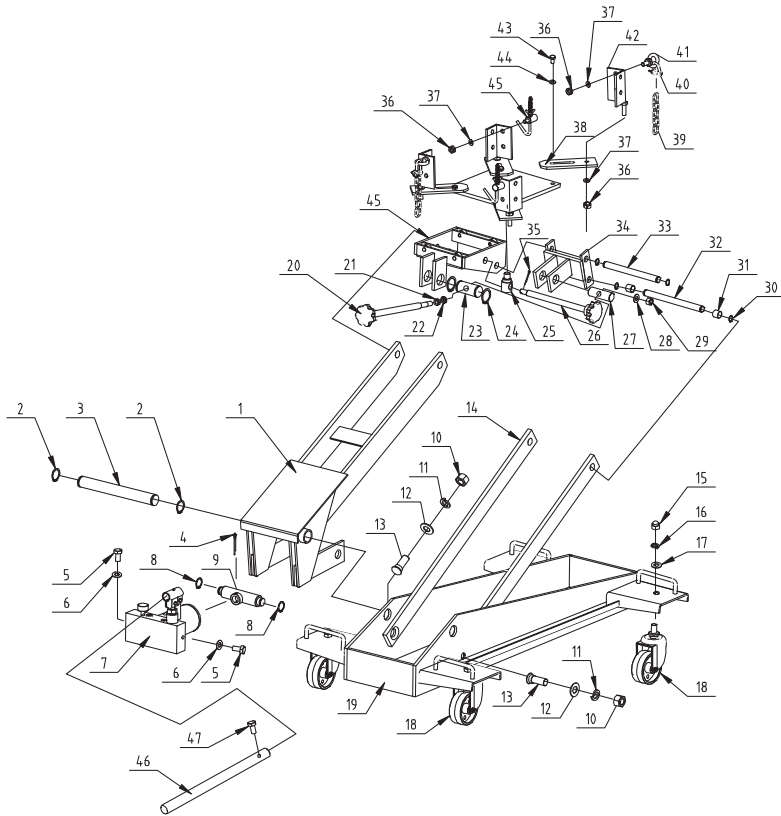

No.	Description	Qty
1	Lifting Arm	1
2	Circlip	2
3	Pivot Shaft	1
4	Split pin	1
5	Bolt	2
6	Flat washer	2
7	Pump	1
8	Circlip	2
9	Pivot for pump	1
10	Nut	2
11	Spring washer	2
12	Flat washer	2
13	Link rod bolt	2
14	Long Link rod	2
15	Cap nut	4
16	Spring washer	4

No.	Description	Qty
17	Flat washer	4
18	Castor wheel	4
19	Frame	1
20	Adjustment screw	1
21	Washer	1
22	Planar bearing	1
23	Actuating pivot	1
24	Ring	2
25	Head copular axle	1
26	Horizontal adjustment screw	1
27	Support pivot	1
28	Flat washer	1
29	Lock nut	1
30	Ring	4
31	Spacer	2
32	Copular axle 1	1

No.	Description	Qty
33	Copular axle 2	1
34	Moving trunnion	1
35	Pivot Shaft	1
36	Nut	8
37	Flat washer	8
38	Adjust bracket	4
39	Chain	2
40	Chain hook	2
41	Lifting bolt	2
42	Saddle bracket	4
43	Socket Bolt	4
44	Flat washer	4
45	Hook assembly	2
46	Handle	1
47	Bolt	1

EC DECLARATION OF CONFORMITY

1. **Product models:** STJV1500

2. **Name and address of the manufacturer or his authorised representative:**



SGS Engineering (UK) Ltd
Unit 1 West Side Park, Raynesway, Derby, DE21 7AZ
Telephone: +44 (0)1332 576 850

3. **This declaration of conformity is issued under the sole responsibility of the manufacturer.**

4. **Object of the declaration:**

Equipment: 1.5 TON HYDRAULIC TRANSMISSION JACK

Brand name: SGS

5. **The object of the declaration described above is in conformity with the relevant statutory requirements:**

Machinery Directive 2006/42/EC

6. **References to the relevant designated standards used or references to the other technical specifications in relation to which conformity is declared:**

Standard(s):
EN ISO 12100:2010 Safety of machinery
EN 1494:2000+A1:2008 Mobile or movable jacks and associated lifting equipment

7. **The person authorized to compile the technical file:**

Name: Neil Sansom

Address: SGS Engineering (UK) Ltd, Unit 1 West Side Park, Raynesway, Derby, DE21 7AZ

Signed for and on behalf of:

Authorised Representative

A handwritten signature in black ink, appearing to read 'Neil Sansom', written over a horizontal line.

Neil Sansom, CEO
Date: 03/25/2026

